

# *Blast Proof Occupied Buildings*



# ***Contents Presentation***

---

- **References**
- **Functional Specification Blast Resistant Building**
- **Basis for design**
- **Blast & impact loading**
- **Design modeling & analyses**
- **Preliminary design**
- **Design details**

# Explosion Analyses & Blast Resistant Design

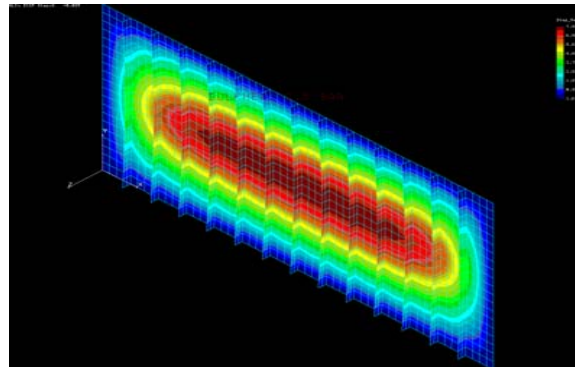
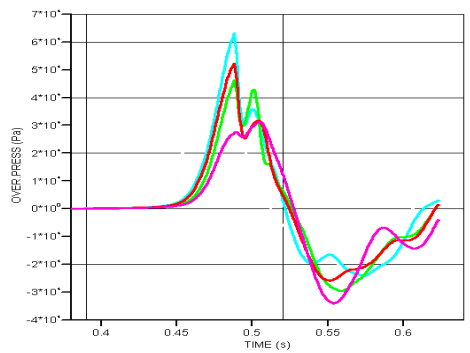
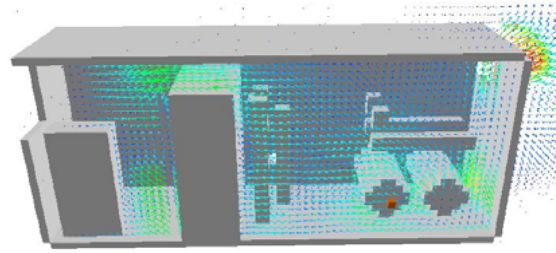
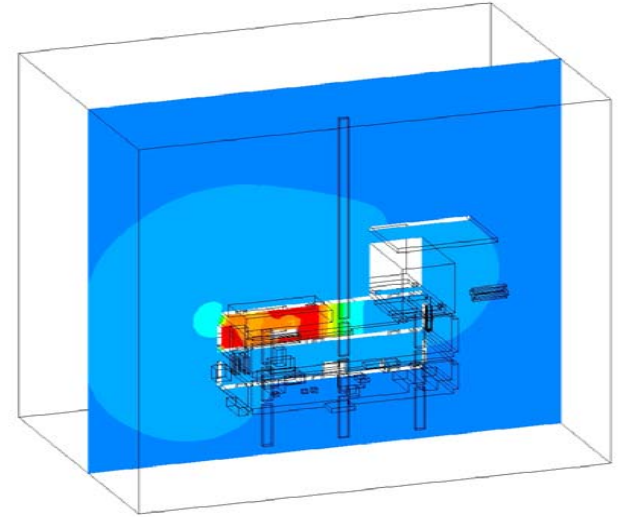
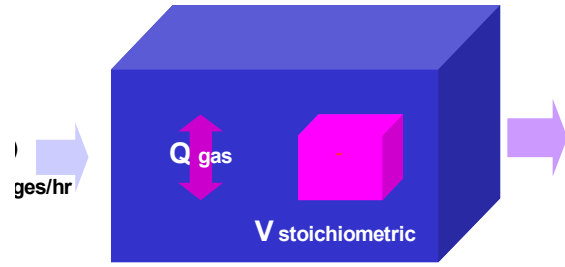

# References Blast Resistant Onshore Modular Buildings

BASF Seal Sands Workshop  
Blast resistance check 0,9 Psi



Shell Pernis for Hertel CKT  
Blast Resistant Modular Building 8 Psi



BP Refineries for Hertel  
Blast Resistant Modular Building 13 Psi

# ATEX 137 Implementation & Training

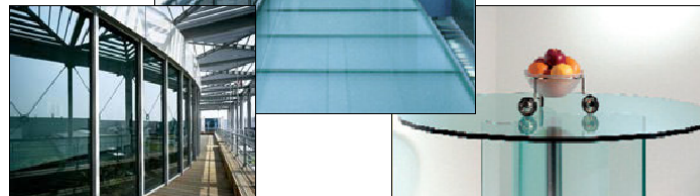

# ***Functional Specification Blast Resistant Building Shell Pernis***

---

- **Frame work structural steel; external walls corrugated plating**
- **Blast overpressure resistance: 970 mbar; 92,3 millisecond**
- **Explosion driven 6 inch, 300 lbs blind flange impact resistance**

# Blast resistant building lay out Shell Pernis

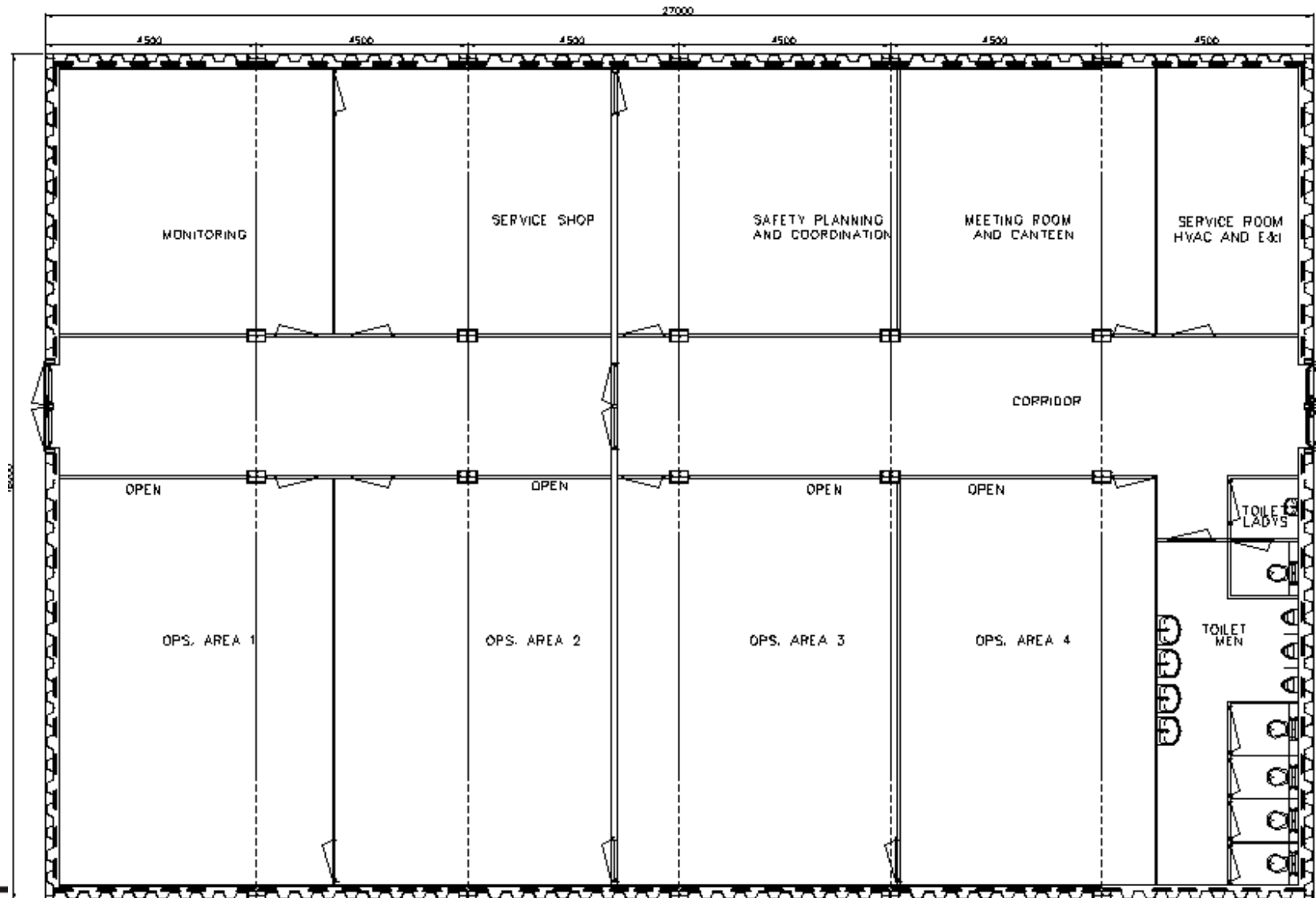

# ***Basis for design specifications; codes & standards***

---

- **Specifications:**
  - GP 04-30  
Guidance on practice for design and location of occupied permanent buildings subject to blast, fire and gas hazards on onshore facilities
  - GP 04-20  
Guidance on Practice for Civil Engineering
  - DEP 34.17.10.30-Gen (optional)  
Technical specification blast resilient and blast resistant control buildings/field auxiliary rooms
- **Codes and Standards**
  - ARMY TM 5-1300  
Structures to resist the effect of accidental explosions
  - PGS 1, part 2B: Effects of explosions on constructions; VROM/SZW;

# ***Basis for design material properties***

- ***Material strength***

Applied yield strength  $F_y = 355 \text{ N/mm}^2$  (St. 52 or equivalent)

Ultimate strength  $F_u = 510 \text{ N/mm}^2$

- ***Dynamic yield stress***

$F_{dy} = F_y \times \text{SIF} \times \text{DIF}$

SIF = Strength increase factor

SIF = 1,1 for structural steel

SIF = 1,2 for cold formed steel cladding panels

DIF = Dynamic increase factor:

DIF = 1.29 for bending/ shear

DIF = 1.19 for tension/ compression

- ***Applied material properties***

*Structural steel*  $F_{dy} = 504/465 \text{ N/mm}^2$  (Bending-Shear/tension-compression)

*Sheeting*  $F_{dy} = 550/507 \text{ N/mm}^2$  (Bending-Shear/tension-compression)

# *Basis for design criteria*

## *Deformation limits*

<b>Element</b>	<b>Ductility</b>	<b>Rotation</b>	<b>Deflection</b>
	$\mu$	$\theta^\circ$	
<b>Beams/girths</b>	<b>20</b>	<b>12</b>	
<b>Frame members</b>	<b>3</b>	<b>3</b>	<b><math>\delta &lt; H/25</math> mm</b>
<b>Metal sheet panels</b>	<b>6</b>	<b>4</b>	
<b>Open web joints</b>	<b>2</b>	<b>2</b>	
<b>Plates</b>	<b>1.5</b>	<b>12</b>	

*Ductility  $\mu$  = Total (plastic) deformation/elastic deformation*

*H = Frame height in mm*

# ***Load combinations***

---

- **Overall strength analysis blast resistant building**
  - Dead weight + frame blast loading
    - Longitudinal direction
    - Transverse direction
- **Local strength analysis wall and roof panels**
  - Reflected over pressure
  - Impact loading walls
- **Floor**
  - Dead weight + live load (3kN/m<sup>2</sup>)
- **Stability**
  - Dead weight + frame blast loading

# *Design modeling & analyses*

---

- **Computer programs & analyses**

- ***Local wall and roof analyses***

The structural impact and response to the blast pressures to the external walls and roof are analysed by means of a time domain non-linear physical excel software.

- ***Overall frame design***

The overall structural blast response calculation is performed with the software STAAD.PRO.

The peak dynamic reactions from the walls and roof are applied to the frame members.

# Design model & analysis outside wall panels

TITLE :	BPB BP Rotterdam Corrugated sheeting outside walls		REV.	DATE	ORIG.	CHKD	KCI APPR.	CLIENT APPR.
CLIENT :	Hertel		1	24/04/2008	D.S			
PROJECT :			2					
DOC NR :			3					
FILE NR :								

## Nonlinear response

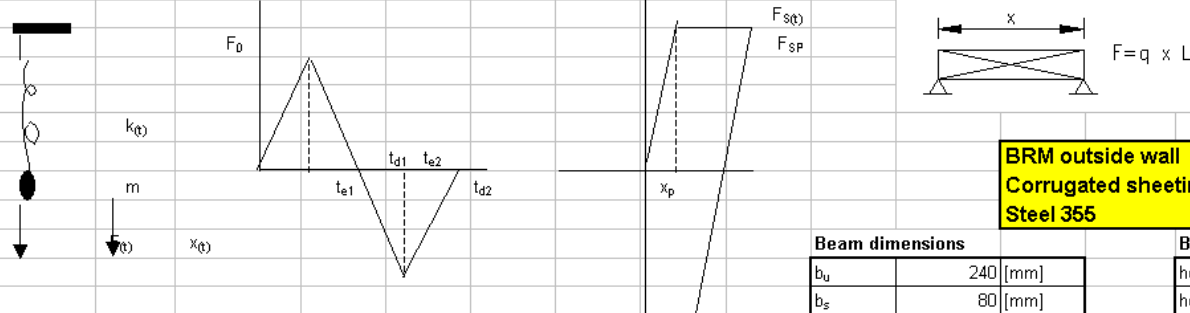

**BRM outside wall**  
**Corrugated sheeting 640/160-8**  
**Steel 355**

## Corrugated sheet

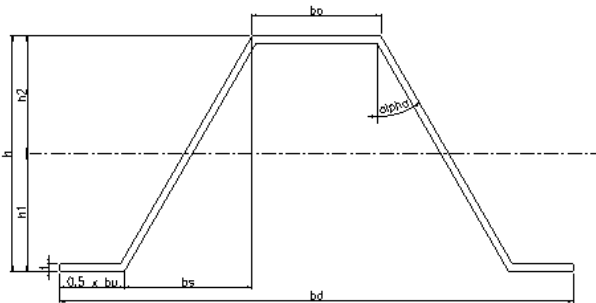

### Beam dimensions

$b_u$	240	[mm]
$b_s$	80	[mm]
$b_o$	240	[mm]
$\alpha$	26.7	[deg]
$h$	160	[mm]
$b_d$	640	[mm]
$t$	8	[mm]
$E$	210000	$N/mm^2$
$\sigma_{yield}$	550	$N/mm^2$

### Beam properties

height <sub>1</sub>	80.0	mm
height <sub>2</sub>	80.0	mm
$z$	80.0	mm
$I_{xx}$	27421121	$mm^4$
$Z_e$	342764	$mm^3$
$Z_p$	421822	$mm^3$
$A$	6706	$mm^2$
$L$	3390	[mm]

### Input data

$k$	22703699	$N/m$
$k$	22703699	$[N/m]$
$m$	178.44	[kg]
$Z_p$	4.2E-04	$[m^3]$
$\sigma_{yield}$	550000000	$[N/m^2]$
$L$	3.39	[m]
$KLMe$	0.78	
$KLMP$	0.66	

### calculated

$M_p$	232002.09	[Nm]
$F_{smax}$	547497.56	[N]
$x_p$	0.024	[m]
$T$	0.0199451	[sec]
$t1/T$	-	
$Me_{el}$	139.18689	
$Me_{pl}$	117.77352	

### Maximum support reaction

Maximum	270623	[N]
Minimum	61132	[N]

DAF = 0.95

Ductility ratio  $\mu = \text{Total deformation/elastic deformation} = 3.8 < \text{Allowable} = 6$   
 Support rotation  $\theta = \text{arctang}(\text{total deformation}/L/2) = 3.1^\circ < \text{Allowable} = 4^\circ$

# Design model & analysis outside wall panels

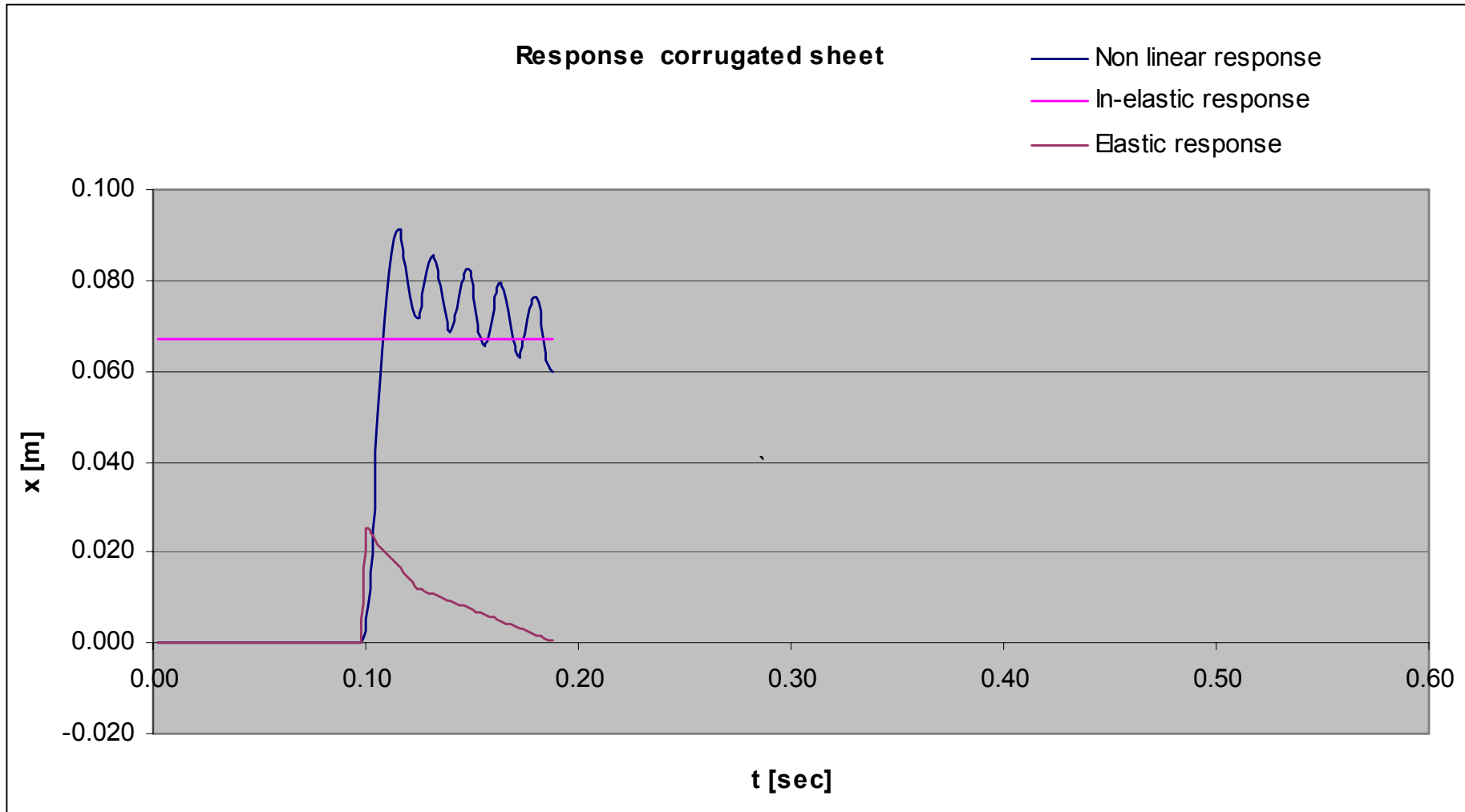

# Design model & analysis outside wall panels

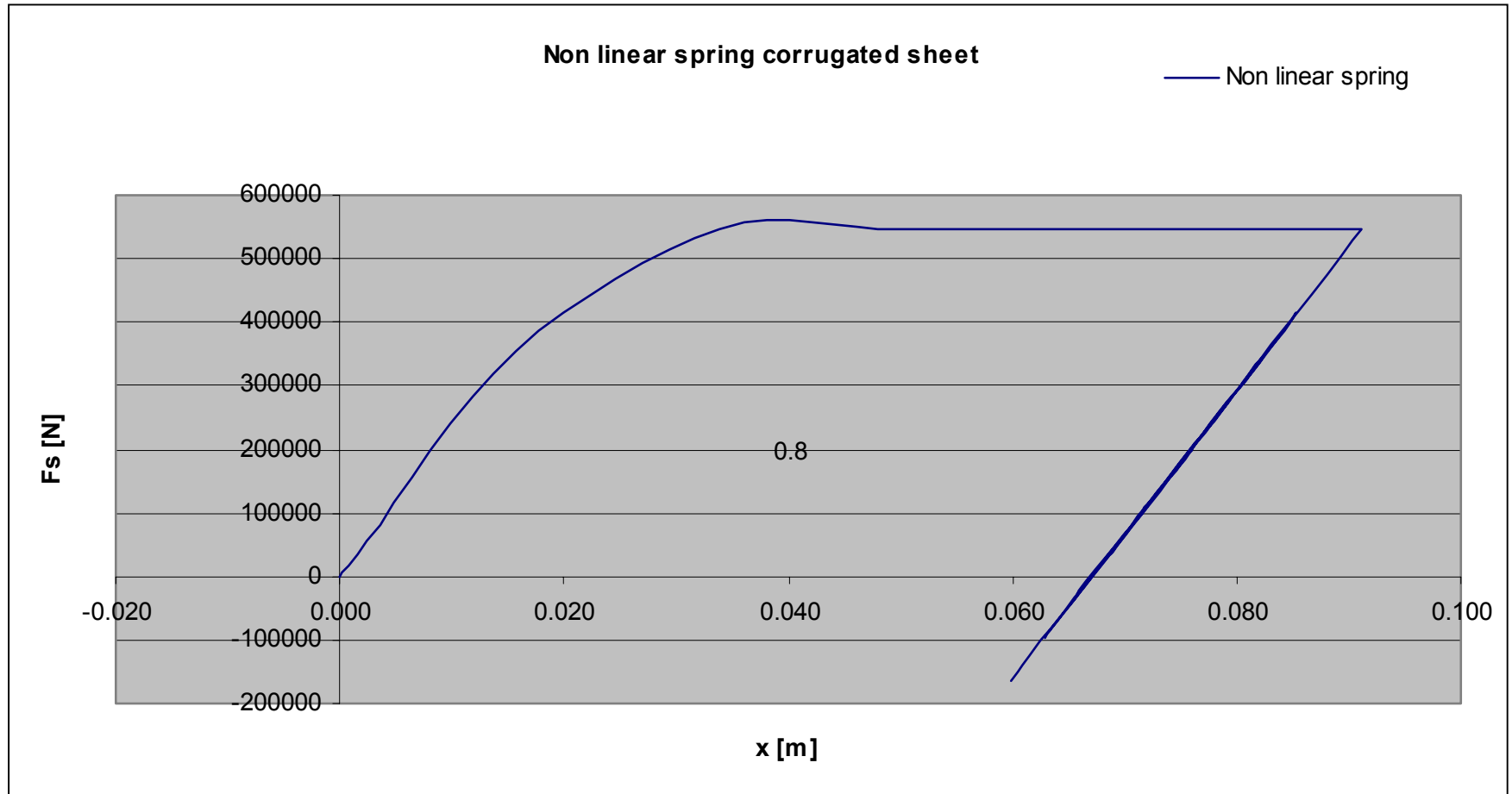

# Design model & analysis outside wall panels

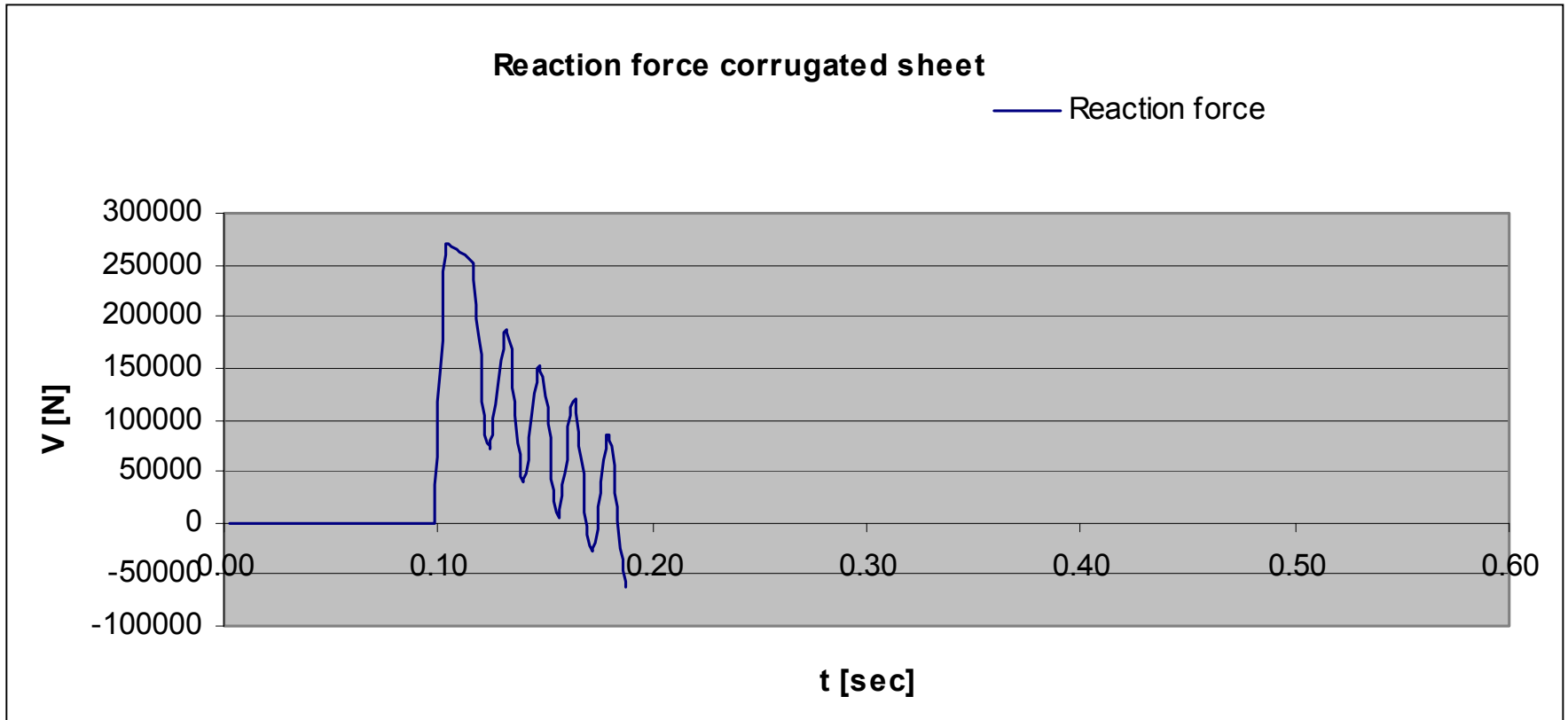

# Design model and analysis roof panels

TITLE : BRB BP Rotterdam roofside walls transvere loading  
 CLIENT : CKT Hertel  
 PROJEC 8022  
 DOC NR  
 FILE NR:



REV.	DATE	ORIG.	CHKD	KCI APPR.	CLIENT APPR.
1	4/24/2008	DS			
2					
3					

## Nonlinear response

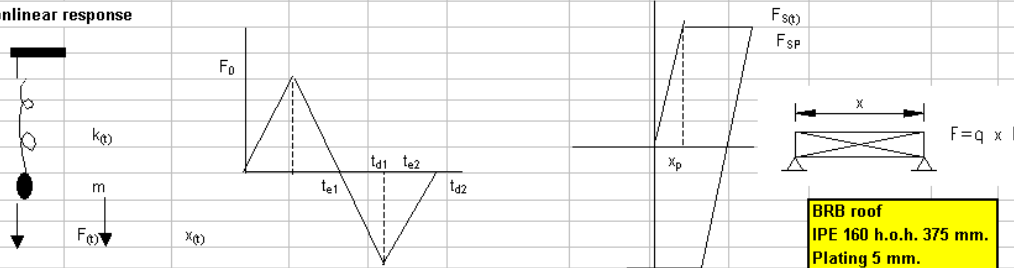

**BRB roof**  
**IPE 160 h.o.h. 375 mm.**  
**Plating 5 mm.**  
**Steel 355**

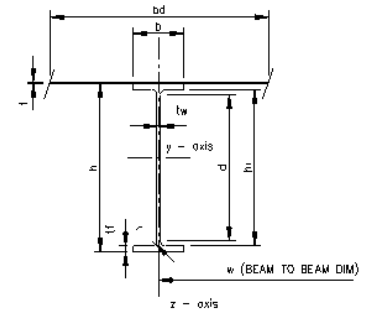

## Input data

k	2739641	N/m
k	2739641	[N/m]
m	124.90	[kg]
Z <sub>p</sub>	7.E-05	[m <sup>3</sup> ]
σ <sub>yield</sub>	504000000	[N/mm <sup>2</sup> ]
L	4.4	[m]
KLM <sub>e</sub>	0.78	
KLM <sub>p</sub>	0.66	

## Beam dimensions / properties

h	160	[mm]
b	82	[mm]
t <sub>w</sub>	5	[mm]
t <sub>f</sub>	7.4	[mm]
r	9	[mm]
A	1939.6	[mm <sup>2</sup> ]
h <sub>i</sub>	145.2	[mm]
d	127	[mm]
I <sub>y</sub>	8692922.28	[mm <sup>4</sup> ]
W <sub>el,y</sub>	108662	[mm <sup>3</sup> ]
W <sub>pl,y</sub>	123953	[mm <sup>3</sup> ]
i <sub>y</sub>	66.9	[mm]
A <sub>wz</sub>	21250	[mm <sup>2</sup> ]
b <sub>d</sub>	335	[mm]
L	4400	[mm]
E	210000	N/mm <sup>2</sup>
σ <sub>yield</sub>	504	N/mm <sup>2</sup>

## Plate dimensions / properties

t	5	[mm]
w	375	[mm]
b <sub>d</sub>	335	[mm]
A <sub>plate</sub>	1676	[mm <sup>2</sup> ]
I <sub>x plate</sub>	3286364	[mm <sup>4</sup> ]
W <sub>el,y</sub>	1314545	[mm <sup>3</sup> ]
W <sub>pl,y</sub>	74186	[mm <sup>3</sup> ]
σ <sub>yield</sub>	504	N/mm <sup>2</sup>
Z <sub>elas</sub>	47	[mm]
Z <sub>pl</sub>	-82.6	[mm]
A <sub>tot</sub>	3616	[mm <sup>2</sup> ]
I <sub>y tot</sub>	14470087.69	[mm <sup>4</sup> ]
I <sub>z tot</sub>	16386706	[mm <sup>4</sup> ]
W <sub>el,y tot</sub>	122371	[mm <sup>3</sup> ]
W <sub>el,z tot</sub>	97747	[mm <sup>3</sup> ]
T <sub>el,x tot</sub>	5138218.258	[mm <sup>4</sup> ]
Z <sub>p</sub>	68727.05586	[mm <sup>3</sup> ]

bd = c x w	335	mm
c = 0.1 + 0.9 log Lo/w =	0.9	
Lo = 0.65 L	2860	mm
Lo/w	7.6	
log Lo/w	0.9	
0.9 log Lo/w	0.8	
A <sub>1</sub>	1676	
A <sub>2</sub>	607	
A <sub>3</sub>	726	
A <sub>4</sub>	606.8	
shear z	726	
shear y	2890	

**DAF = 1.04**

## Support reaction

Maximum	33634	[N]
Minimum	485	[N]

Ductility ratio  $\mu$  = Total deformation/elastic deformation = 5.2 < Allowable = 20  
 Support rotation  $\theta$  = arctang (total = deformation/2L) = 4.1 ° < Allowable = 12 °

# Design model and analysis roof panels

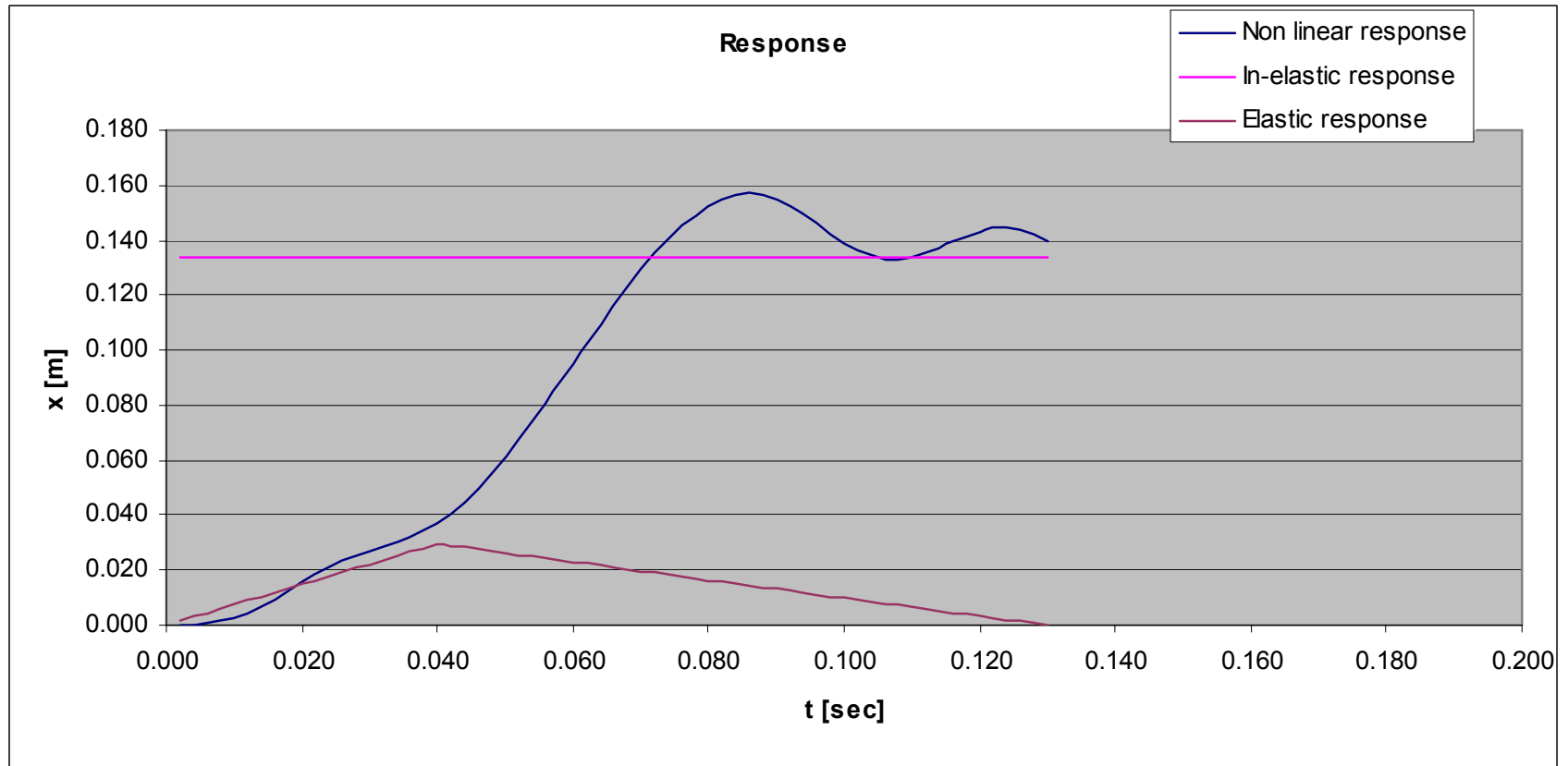



# Fragment impact analysis

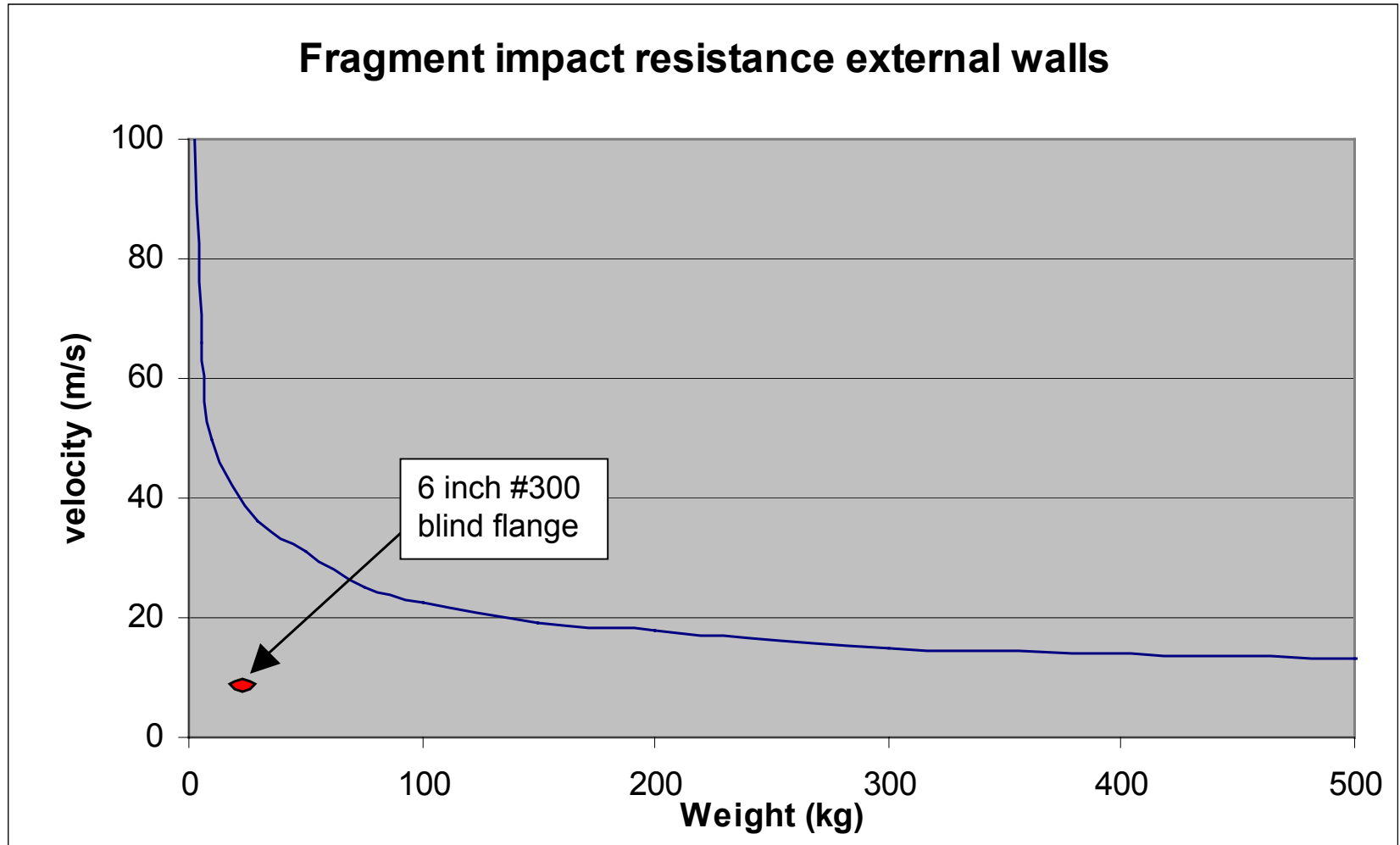

# *Blast resistant frame model & analysis*

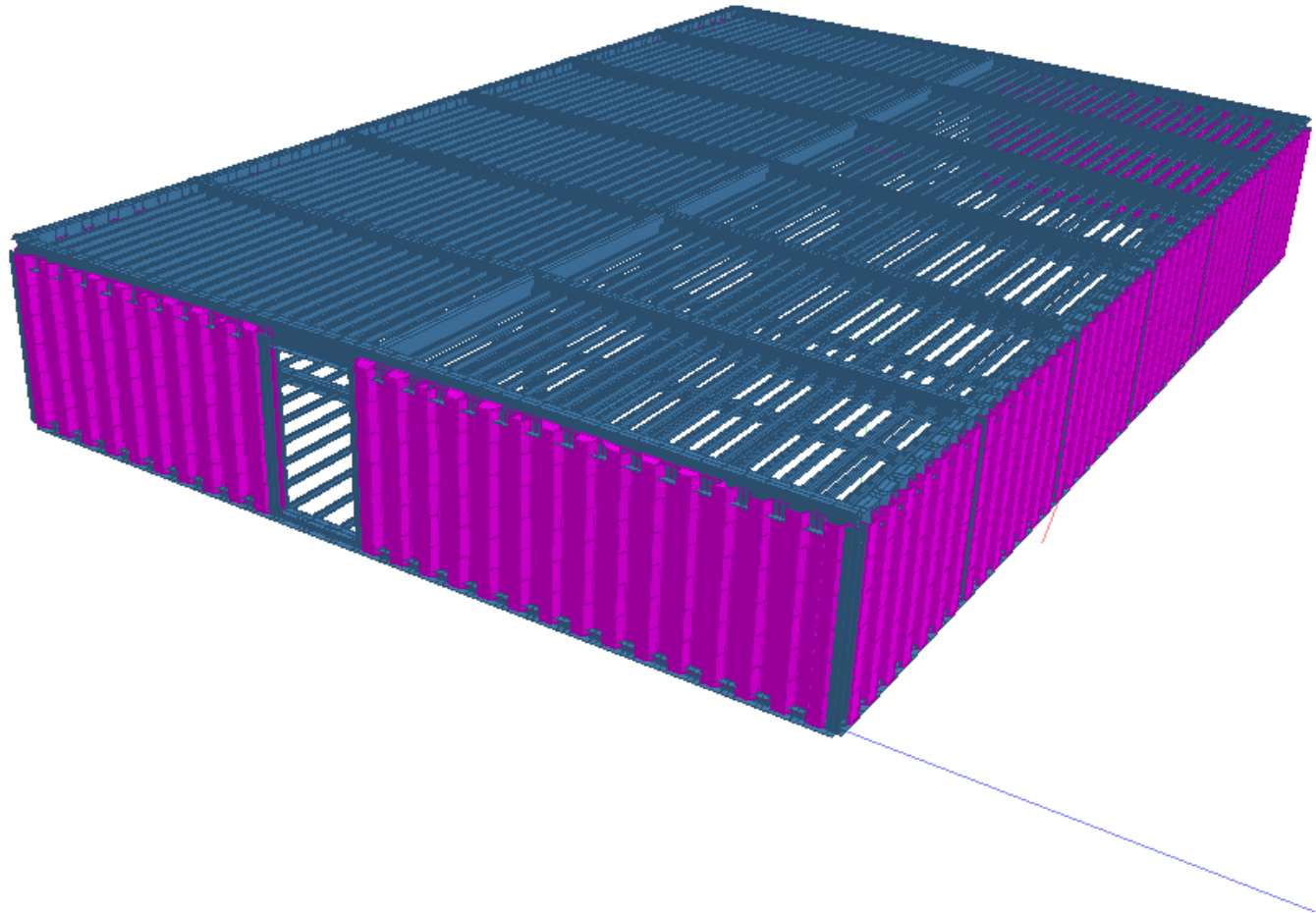

# *Blast resistant frame model & analysis*

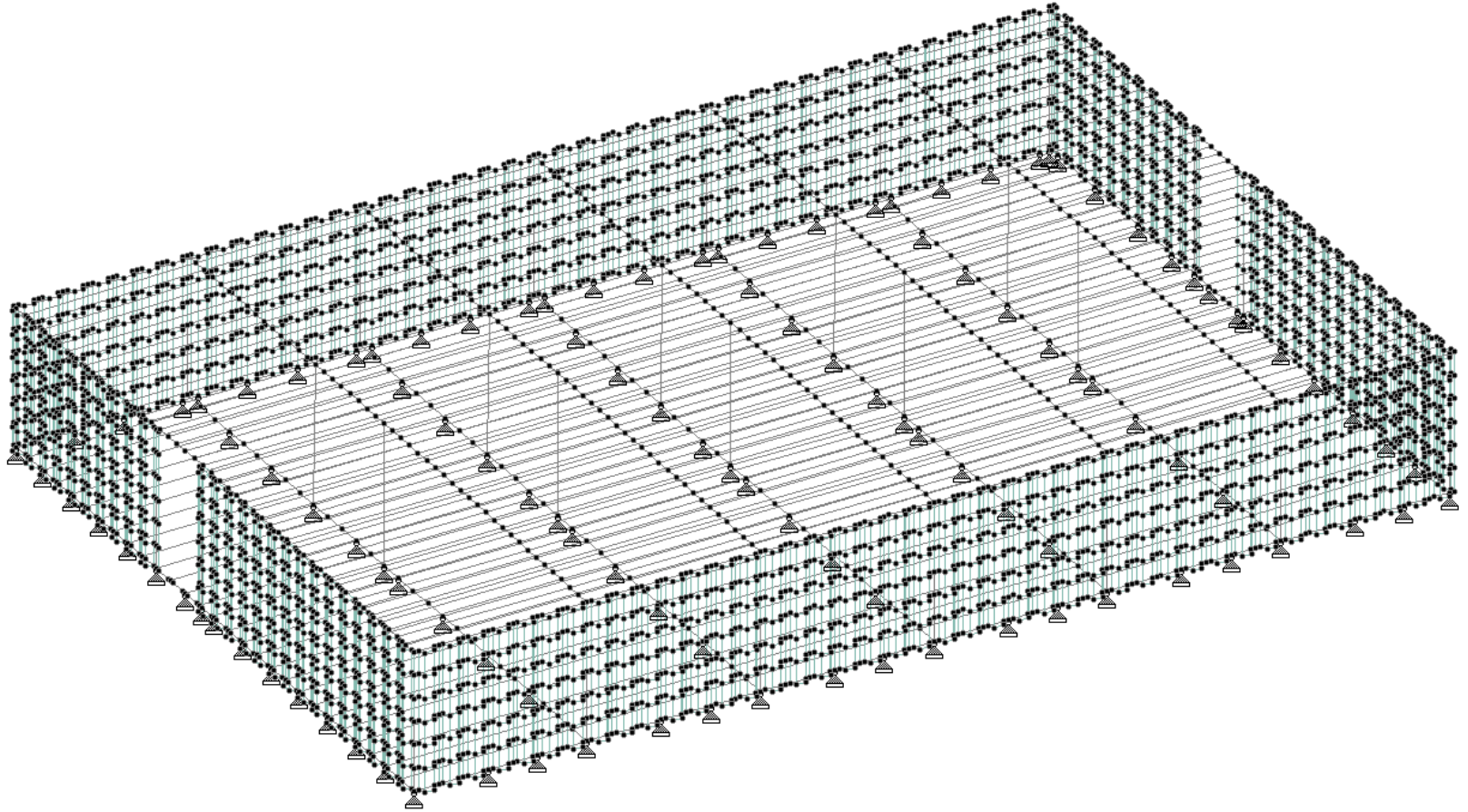

# Blast resistant frame model & analysis

Roof

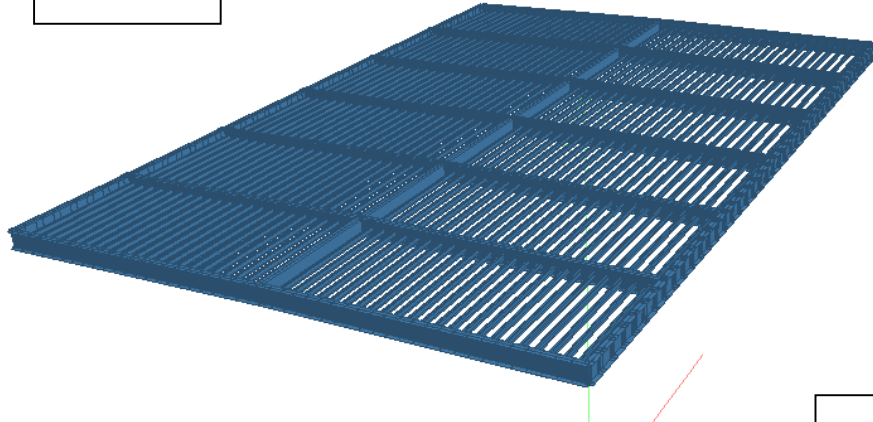

Floor

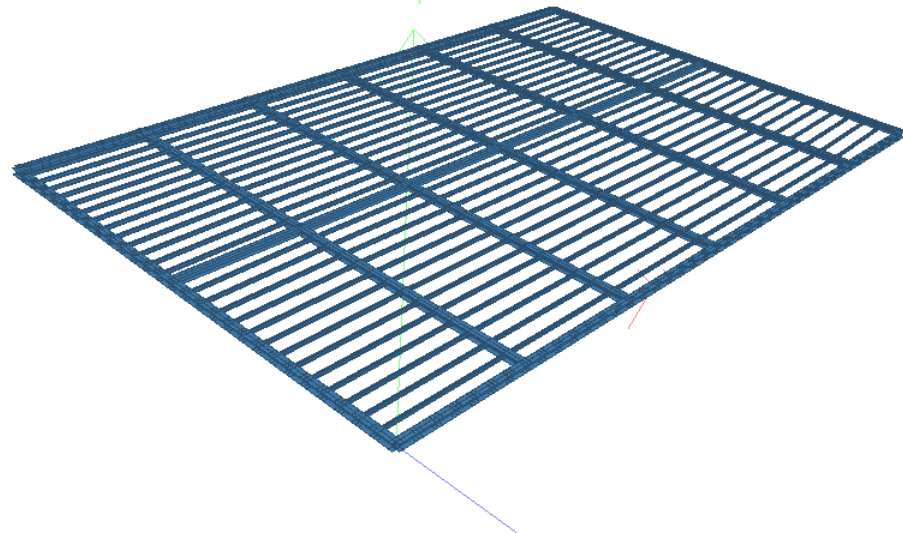

# Blast resistant frame model & analysis

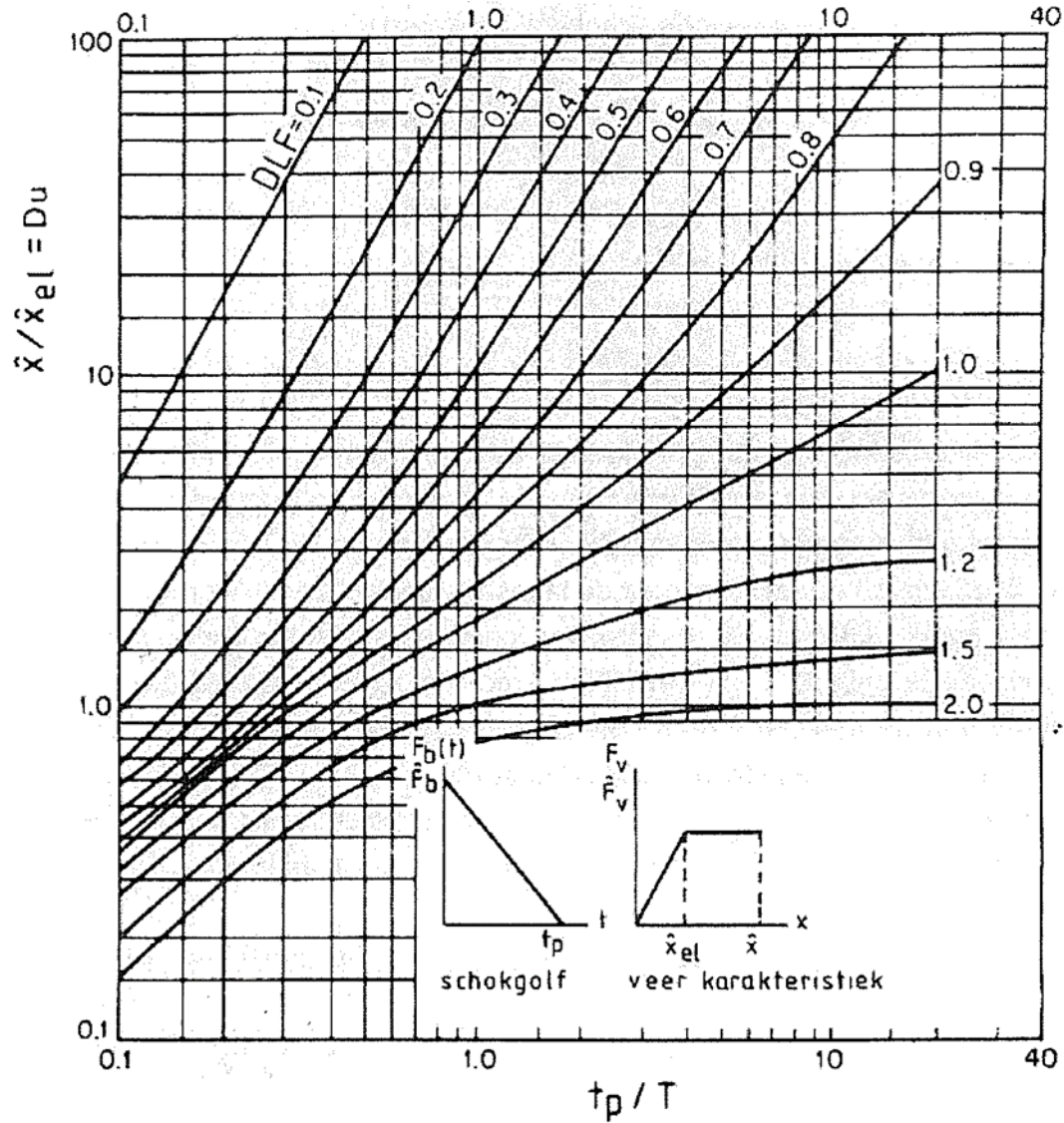

# Design details

- Doors
- Windows
- Ducts
- Piping

